

Specific Assembly Instructions

The upper membrane is glued to the upper cover after etching using a glue gun.

- The Battery is glued to its support using a glue gun.
- The lower membrane is glued to the foot using a glue gun.
- The nuts are embedded in the parts in specific housings.

Ex :

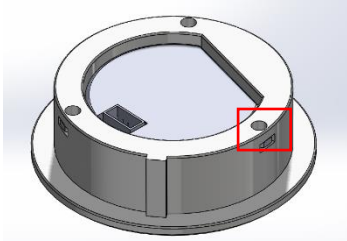

- The Electronic card - Bluetooth card cable is plugged into the right connector of the electronic card
- The Electronic card-Battery cable is connected to the left connector of the electronic card

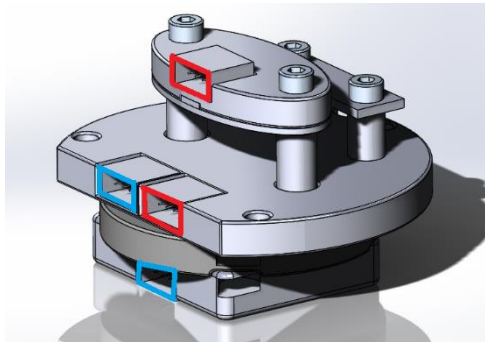

- The vibrating pot - Electronic board cable is connected to the connector of the vibrating pot then soldered to a matrix board screwed onto the electronic board (in blue).

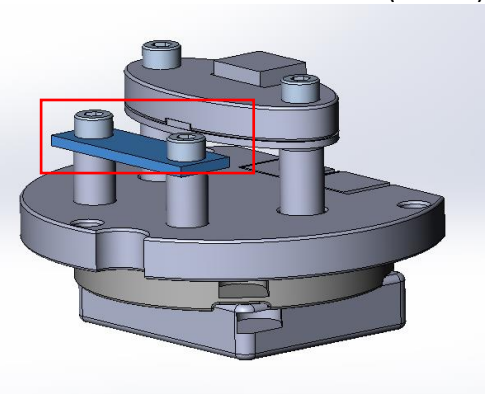

Assembly Range

Set : Connected Speaker

N°	Opérations	Pieces	Diagrams	Tools	Estim ated Time

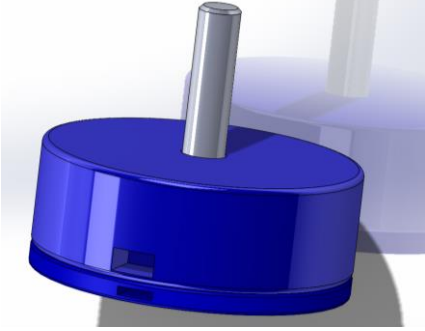
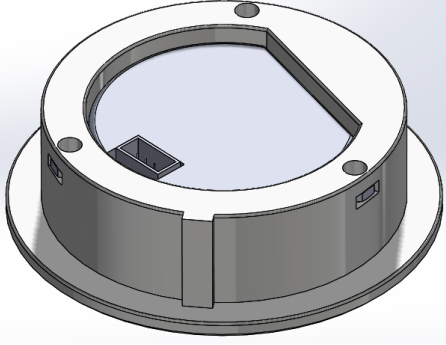
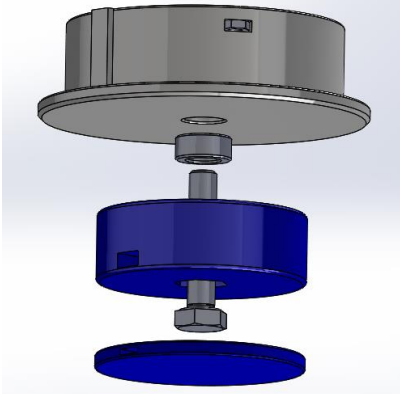
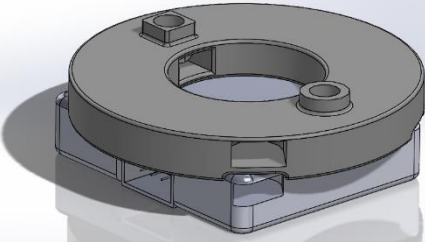
10	<p>Magnetize the lower membrane on the support.</p>	<p>1 - 2 - 3</p>			5s
20	<p>Place the vibrating pot in the bottom lid.</p>	<p>8 - 5</p>			5s
30	<p>Place the strut between the support and the lower lid and screw on the lower assembly.</p>	<p>1 - 2 - 3 - 4 - 5</p>			30s
40	<p>Attach the battery on its support with magnets.</p>	<p>10 - 11</p>			5s

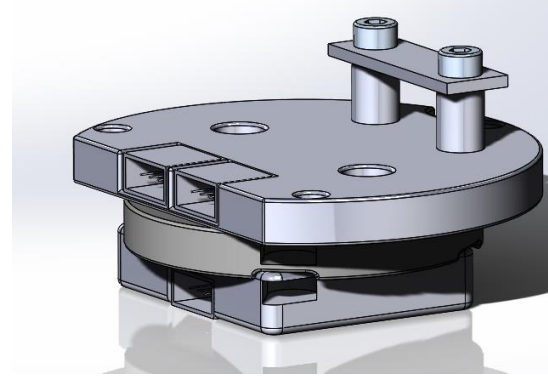
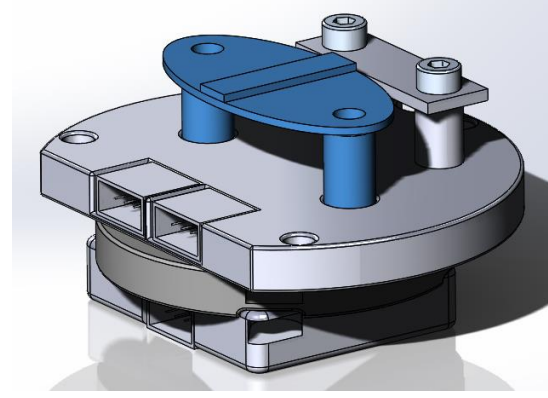
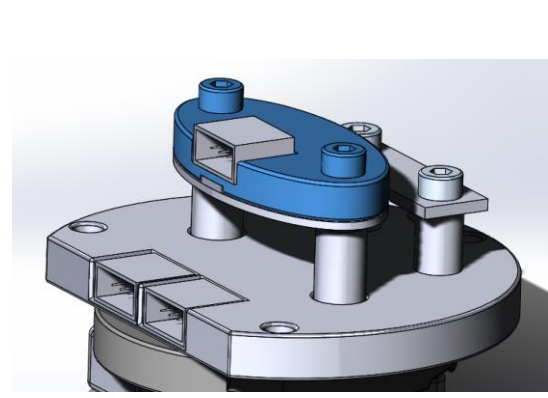
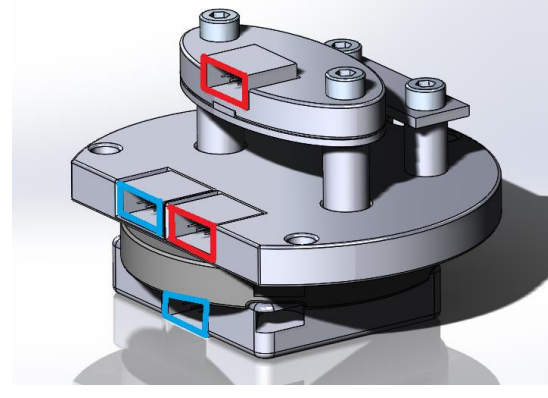
50	Assemble the battery support on the electronic board.	15			10s
60	Set the Bluetooth card support on the electronic card.	17			5s
70	Screw the Bluetooth card on its support.	19 – 20 (2 Screw CHC M3 x 25 mm)		Tools: Screwdriver for CHC screw	30s
80	Connect the elements: -Bluetooth card -Electronic card -Battery -Electronic board	2 cables grove 4 pins			30s

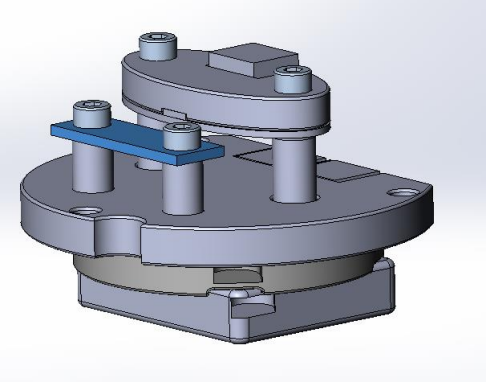
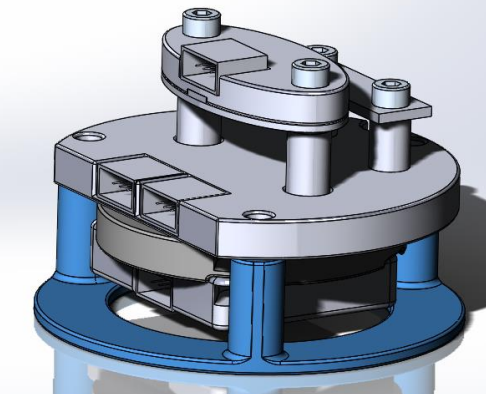
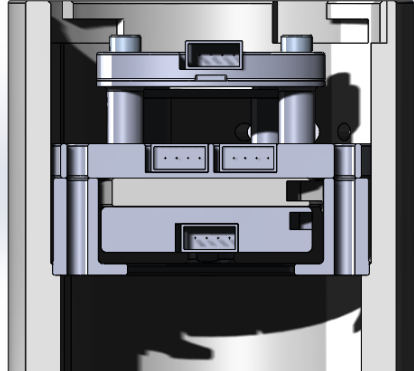
90	<p>Weld the four power connector pins of the stripped cable to the die.</p>	<p>1 cable pins stripped on one side grove 4</p>		<p>Tool : Welding machine</p>	120s
100	<p>Place the electronic assembly on the motherboard support.</p>	<p>9</p>			10s
110	<p>Place the electronic set on the body step being careful about the cables</p>	<p>21</p>			20s
120	<p>Link the previously welded cables with the vibrating pot</p>				10s

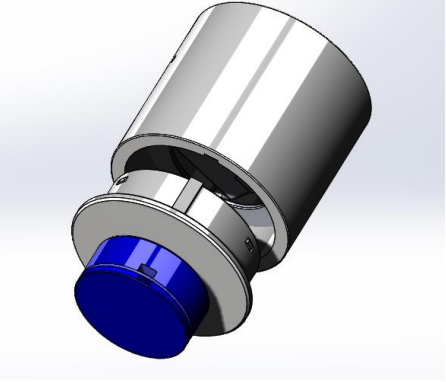
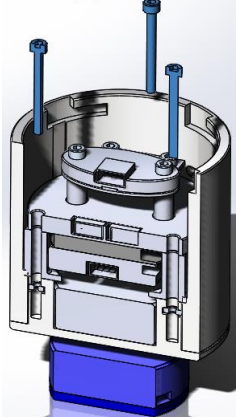
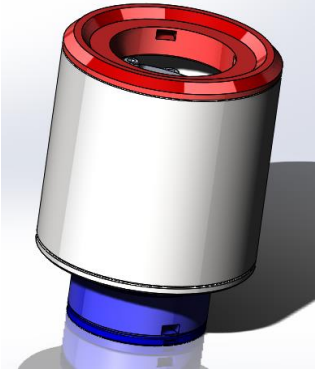
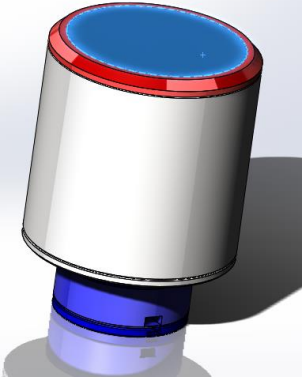
130	Place the body on the inferior set				10s
140	Screw the inferior set with the electronic set	12 : 3 vis M3 x 30mm		Tool : ScrewDriver	60s
150	Screw the upper lid to the body	22			5s
160	Magnet the upper membrane to the top lid	23			5s